

Hussmann Milk, Egg and Dairy Cabinet (HVRP)

A refrigerated milk merchandiser, the cabinet is designed to suit Tetrapak "H" milk crates.



HVRP - Milk/Egg and Dairy Cabinet

Introduction

The HVRP is a refrigerated milk merchandiser. The cabinet is designed to suit Tetrapak "H" milk crates. These allow for return air to flow under the product. There are two refrigerated shelves for dairy/deli display. The case has a low front counterweight lift door for easy loading. The cases can be made in a variety of lengths. This case can be modified for egg merchandising.

Standard Features and Options

	Standard	Optional
Solid End Panels	✓	
Mirrored End Panels		✓
Two Shelf Rows	✓	
Shelf Lighting		✓
Double Row Canopy Lighting	✓	
Econocovers - Night Blinds		✓
Front Lift Door	✓	
Door Counterweight	✓	
Digital Solar Thermometer	✓	
Choice of Colours	✓	
Black Impact Bumper		✓
Black Vinyl Cart Bumper		✓
Custom Heights and Lengths		✓
Number of Crates in:		
2400 case = 40		
3600 case = 56	✓	
3700 case = 64		
Open Height with Door lifted 1400mm	✓	

Dimensions

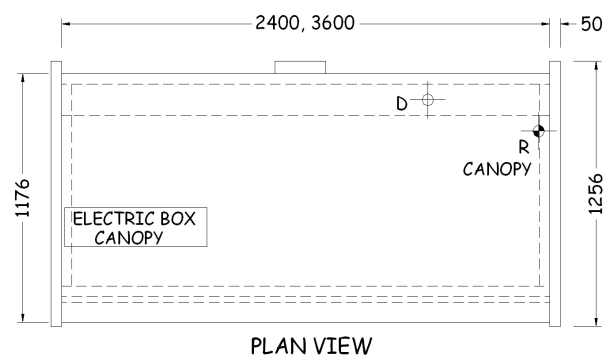
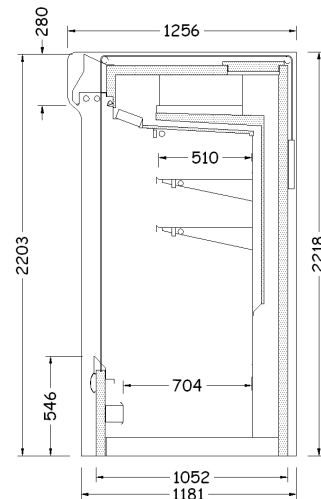

Also Available

HVRR - Rear Load

Dimensions and Features are subject to change. Please obtain current information prior to order confirmation.

Note: We reserve the right to change or revise specifications and product design in connection with any feature of our products. Such changes do not entitle the buyer to corresponding changes, improvements, additions or replacements for equipment previously sold or shipped.