

Hussmann Multi-Deck Hot Serve (RHR-2)

An island case with a hexagonal footprint which can merchandise up to 48 packaged chickens presented in single layers.



RHR-2 Hex - Two-Tier Chicken Island

Introduction

The RHR-2 Hex is an island case with a hexagonal footprint. It can merchandise up to 48 packaged chickens presented in single layers. The RHR can be supplied in half-island version, as well as a wall model having the same profile as the island case.

The controls include an indicator for when the case is ready for loading, and another indicator for when it is cool enough to clean. Full OSH labelling and heat guards are fitted as standard on the cabinet.

A promotional light box which fits on top of the canopy is also available as an option.

Dimensions

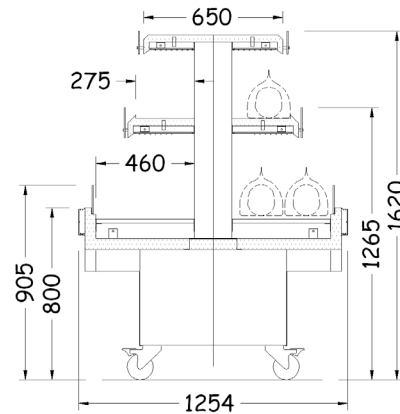

Standard Features and Options

	Standard	Optional
Stainless Steel Construction	✓	
Heat Controls Behind Lockable Panel	✓	
Electric Box Front Lower Access	✓	
Halogen Lighting on Both Levels	✓	
Polycarbonate & Acrylic Heat Guards	✓	
Lockable 125mm Castors	✓	
Temperature Indicators	✓	
Bumper Type and Colour		✓
Lower Painted Panels		✓
Fixed Base (Variable Height)		✓
Power Supply through Canopy or Base		✓

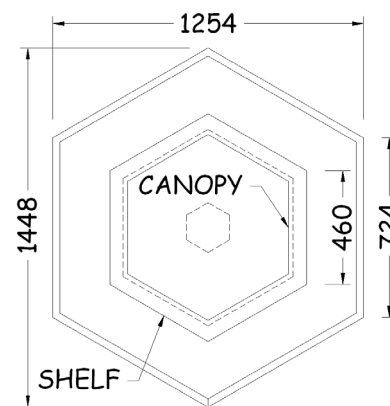

Dimensions and Features are subject to change. Please obtain current information prior to order confirmation.

Note: We reserve the right to change or revise specifications and product design in connection with any feature of our products. Such changes do not entitle the buyer to corresponding changes, improvements, additions or replacements for equipment previously sold or shipped.